

PLANT VIEW
VISTA SUPERIOR

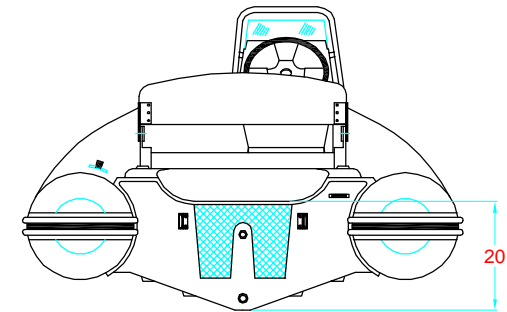

AFT VIEW
VISTA TRASERA

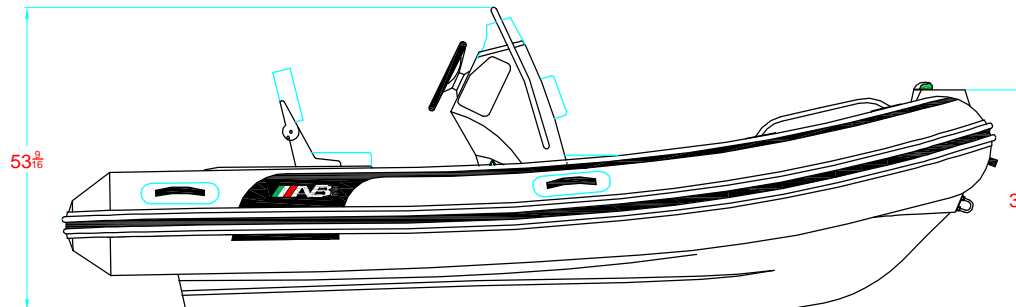

LONGITUDINAL PROFILE
VISTA LATERAL

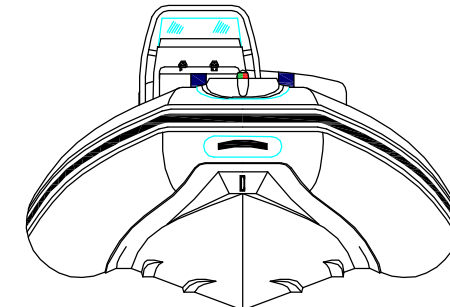

FORE VIEW
VISTA FRONTAL

MAIN PARTICULARS

MAXIMUM LENGHT/ESLORA MAX. _____ 14' (4.27m)
 MAXIMUM BEAM/MANGA MAX. _____ 6' 5" (1.96m)

NOTES: 1.-ALL DIMENSIONS IN INCHES
 TODAS LAS MEDIDAS ESTAN DADAS EN PULGADAS

SUBJECTED: ALEXANDER BARRIOS		TITLE: "OCEANUS 14 VST " GENERAL ARRANGEMENT ARREGLO GENERAL					
APPROVED: HERMES GARCIA		SCALE:	SHEET: 1/1	CODE:	PLAN: ARTIGI.14 VST		
				DATE 03.08.12		DRAWN HECTOR SUAREZ	
				DATE		APPROVED:	